

# DrizAir 80 Deluxe with Pump Dehumidifier

(F265, F265-SP, F265-230V UK)

## Symbol Definition

newer components.

\* - means multiple components to choose from for different models: voltage, size, color, et

+ - means if you order this item, you may need to order additional items marked with same # of +'s in order to upgrade or complete repair

Find#	Part Description	Specifications/Model	Part #	Qty
	Connector	Butt Fully Insul 16-14 Ga	02-00013	ea. 1
5	Terminal Block	4 x 4	02-00078	ea. 1
	Wire	Blue 14Ga Awm 105c/600v	02-00097	ft. 1.17'
	Wire	Red 14Ga Awm 105c/600v	02-00099	ft. 1.42'
	Wire	White 14Ga Awm 105c/600v	02-00101	ft. 1.58'
	Wire	Black 14Ga Awm 105c/600v	02-00102	ft. 1.46'
	Wire	Orange 14Ga Awm 105c/600v	02-00111	ft. 0.83'
	Connector	Qc .250 Fem 90° Fully Insul 16/14 Ga	02-00133	ea. 2
	Connector	Qc .250 Fem Fully Insul 16/14 Ga	02-00135	ea. 10
41	Strain Relief	Snap .360 Dia Blk	02-00218	ea. 2
30	Switch	Rocker Dpdt 115v Blk (On/Off/Purge)	02-00266	ea. 1
32	Handle	Flush Mount	03-00002	ea. 1
18	Foot	1.125" Dia x .875" Rubber Blk	03-00003	ea. 4
69	Spacer	Nylon, Handle	03-00009	ea. 4
	Cable Tie	Nylon 4"	03-00012	ea. 8
45	Washer	3/16" Rivet Zp W-6	03-00013	ea. 8
6	Screw	#8 x 1/2" Pan Hd Phil Sms Zp	03-00023	ea. 1
58	Cap	Plastic Blk 1.125 Dia.	03-00027	ea. 1
72	Nut	1/4-20 Nylon Insert Thin Zp	03-00029	ea. 2
9	Nut	w/ Star Washer 10-24 Zp	03-00038	ea. 6
19	Rivet	3/16" x 5/8" Stl/Stl Zp Ssp 6-10	03-00039	ea. 4
71	Knob	Star w/ 1/4 x 20 Insert Blk Top In	03-00056	ea. 2
28	Plug	.187 Nylon Black	03-00071	ea. 4
59	Bolt	Carriage 1/4-20 x 2 1/4 Zinc Plate	03-00072	ea. 2
2	Screw	#10 x 3/8" AB Shwh Zp Blk	03-00079	ea. 13
12	Bolt	5/16"-18 x 1 1/2 Lg Hex Hd Cap Zinc	03-00085	ea. 4
11	Washer	3/8" I.D. x 7/8" OD x .07 Zp	03-00086	ea. 8
13	Nut	Nyloc 5/16"-18 Zp	03-00098	ea. 4
57	Grommet	.75 ID x 1.375 OD Rubber	03-00179	ea. 1
1	Rivet	Stl/Stl SB6-4 Z1X Blk	03-00432	ea. 18
52	Clamp	3/8" ID Hose Green	03-00471	ea. 1
64	Bolt	Oval Hd Phil 10-24 x 7/, Axle	03-00490	ea. 3
65	Nut	Nyloc 10-24 Zinc, Axle	03-00491	ea. 3

Find#	Part Description	Specifications/Model	Part #	Qty
60	Pin	Hitch, #17 Zp	03-00501	ea. 2
61	Washer	1 1/4" x 1/2" x .062 SS	03-00502	ea. 4
68	Bolt	Oval Hd Phil Mach 1/4-20 x 1, Handle	03-00503	ea. 4
	Cable Tie	11"	03-00813	ea. 0.2
39	Screw	HWH Class 2 Tf 8-32 x 1/4	03-00962A	ea. 2
54	Hose Clamp	Hose, 1/2" Dia Spring Teel UM5 Yellow	03-01059	ea. 2
25	Screw	10-24 x 1/2" Slot Hwh Zp	03-01429	ea. 4
	Foam Wrap	6" x 6" Perf White Psa .125 Thick	06-00035	ea. 3
	Insert	Foam 1# EPS 15.5 x 10.5 . 5.5	06-00043	ea. 1
	Box	21" x 19.5" x 25.25" 275# Dw Kraft	06-00044	ea. 1
	Foam	Side 2.75" x 2.75" x 21" Eps 1lb	06-00048	ea. 2
42	Label	Operating Instructions	07-00050	ea. 1
74	Label	230v, Model/Serial CE Dehu	07-00162	ea. 1
56	Label	Model/Serial 115v UL/CUL Dehu	07-00165	ea. 1
	Manual	230v, Owners CE Dehu (F265-230v UK)	07-00212	ea. 1
	Manual	115v, Owners Dehu Warranty Card	07-00265	ea. 1
31	Label	Product, DrizAir 80 (F265, F265-230v UK)	07-00299	ea. 1
16	Label	Caution Y/B Dehumid	07-01432	ea. 1
26	Coil Assembly	Evaporator / Condensor	08-00023	ea. 1
17	Base	Galvanized	08-00064	ea. 1
29	Cover Assy	w/ Finish Fisher Blue (F265, F265-230v UK)	08-00081	ea. 1
34	Filter Shroud	w/ Finish Pc Wr Blk	08-00083	ea. 1
33	Filter	12.4 x 10 x .43 25 Ppi Blk	08-00089	ea. 1
3	Fan Shroud Assy *	Fan shroud assy- 8" 9W 115v	08-00095	ea. 1
22	Gasket	1/2" x 3/16" x 51 Psa	08-00097	ea. 1
27	Gasket	Condenser Psa	08-00102	ea. 1
24	Hose Wrap	Wire Form w/Pc Wr Blk	08-00114	ea. 2
76	Fan Shroud Assy *	Fan shroud assy- 230v 8"dia 9W	08-00119	ea. 1
66	Leg	w/ Finish Pc Wr Blk	08-00126	ea. 2
67	Folding Handle	w/ Finish Pc Wr Blk	08-00128	ea. 1
63	Axle	1/2 Dia x 18.5 Nickel Plate	08-00130	ea. 1
14	Refrigeration Lines	115v	08-00135	ea. 1
	Refrigerant	R-134a (\$25 Flat Fee) (Heat Pipe)	08-00139	oz. 12
10	Compressor	115v, 3926 BTU Reciprocating R134a	08-00141	ea. 1
23	Drip Tray	ABS Blk	08-00142	ea. 1
38	Flange	Filter Shroud ABS	08-00143	ea. 2
8	Valve	5/16" Line Service	08-00144	ea. 1
49	Pump ***	115v, Centrifugal 80 Gph 5 Ft Cord	08-00177	ea. 1
78	Pump ***	230v, Centrifugal 80 Gph 5 Ft cord	08-00197	ea. 1
40	Power Cord Assy *****	115v, 16/3 Sjt 5-15P 25 Ft	08-00204	ea. 1
48	Overload *****	115v, Compressor (F265, F265-SP)	08-00239	ea. 1
37	Cover	Terminal 3- 1/4 x 2-1/8 x 1/34 Plastic	08-00246	ea. 1
20	Grommet	0.500 ID x 1.125 OD Rubber Blk	08-00249	ea. 4
47	Relay *****	115v, PTC Compressor (F265, F265-SP)	08-00250	ea. 1

Find#	Part Description	Specifications/Model	Part #		Qty
46	Clamp	Terminal Cover Spring Stl	08-00251	ea.	1
43	Clip	115v, Compressor Overload	08-00252	ea.	1
15	Sleeve	115v, .375 ID x .500 OD Compressor	08-00253	ea.	4
	Microswitch +	115v/230v (for pump)	08-00298	ea.	1
	Screw +	Microswitch, Centrifugal pump	08-00299	ea.	2
	Nut +	Microswitch, Centrifugal pump	08-00300	ea.	2
	Washer, lock +	Microswitch, Centrifugal pump	08-00301	ea.	4
75	Compressor	230v, Reciprocating 3756 BTU	08-00307	ea.	1
79	Defrost Control **	115v/230v , Thermostat Spst	08-00308	ea.	1
80	Relay *****	230v, PTC Compressor (F265-230V UK)	08-00309	ea.	1
81	Overload *****	230v, Compressor (F265-230V UK)	08-00310	ea.	1
82	Capacitor	230v, 30MFD 330v 50/60Hz	08-00313	ea.	1
83	Cover	230v, Terminal 3-3/16 x 2-3/4 x 2-1/4	08-00317	ea.	1
84	Clamp	230v, Terminal Cover Spring Stl	08-00318	ea.	1
	Insulation	Pipe, 3/8" ID x 3/8" Wall	08-00785	ft.	3
	Tape	1" Blk Med Psa Resil (3")	13-00003	ft.	.25'
70	Foot	1" Blk Rigid Rubber Foot (For Handle)	13-00510	ea.	2
62	Wheel	9" x 1.75" x 1/2" Bore Black	13-00861	ea.	2
44	Plug	Metal Zp, 1" OD	13-01190	ea.	4
50	Tubing, Vinyl	1/4" ID x 3/8" OD (Sold in qty of 40' only)	15-00195	ft.	40'
55	Tubing, Vinyl	3/8" ID x 1/2" OD (2")	15-01058	ft.	0.17'
51	Tubing, Vinyl	1/2" ID x 3/8" OD (5")	15-01463	ft.	0.417'
35	Hose End	1/2" HB Tcf-74	18-00508	ea.	1
	Tubing	1/4" Copper Soft AC/R	18-00757	ft.	3.13'
	Tubing	5/16" Dia Soft Copper Tube AC/R	18-00765	ft.	3.49'
53	Hose Barb Fitting	3/8 x 1/4 Connector	18-01052	ea.	1
	Microswitch Kit +	incl. screws, nuts, washers	S262	ea.	1

# DrizAir 80 Deluxe with Pump Dehumidifier

F2650

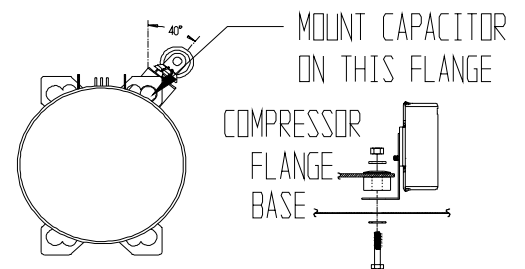
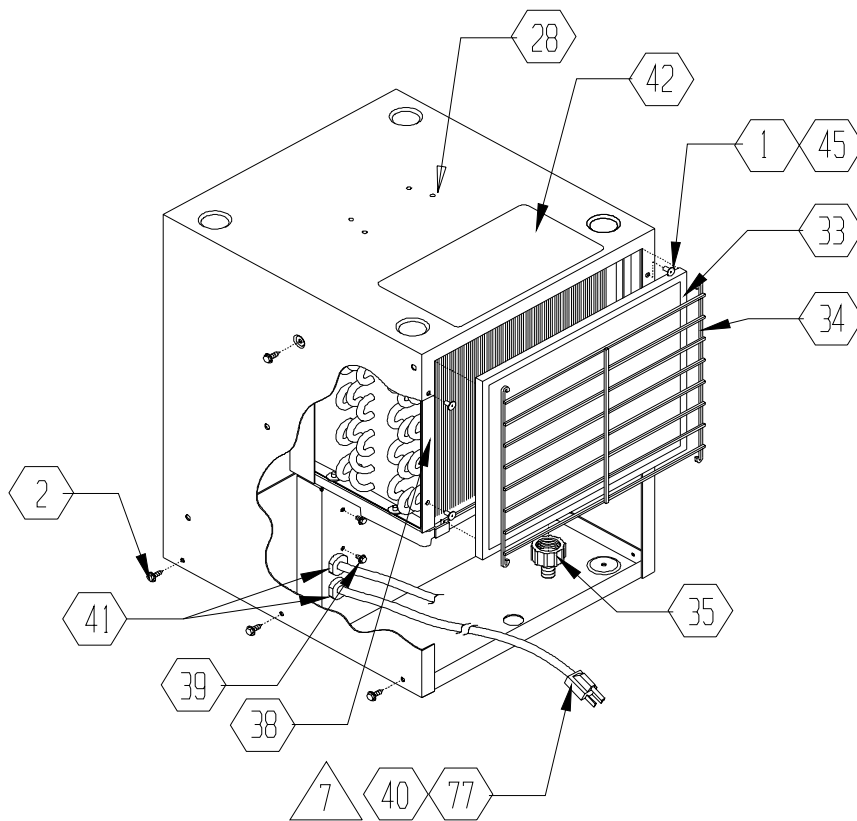

CAPACITOR MOUNTING DETAIL  
 ( -230V UK ASSEMBLY ONLY )

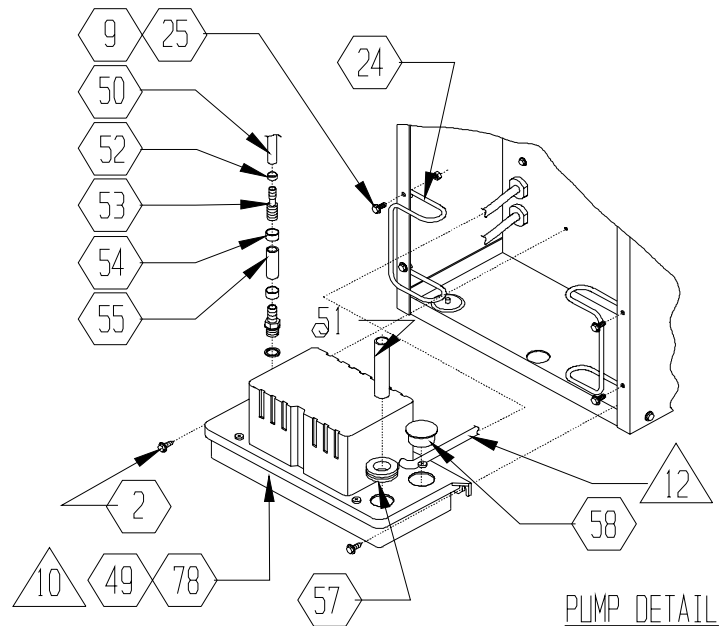
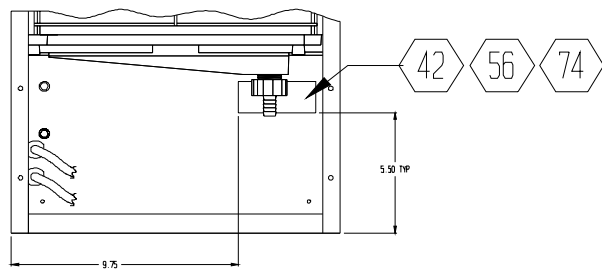

# DrizAir 80 Deluxe with Pump Dehumidifier

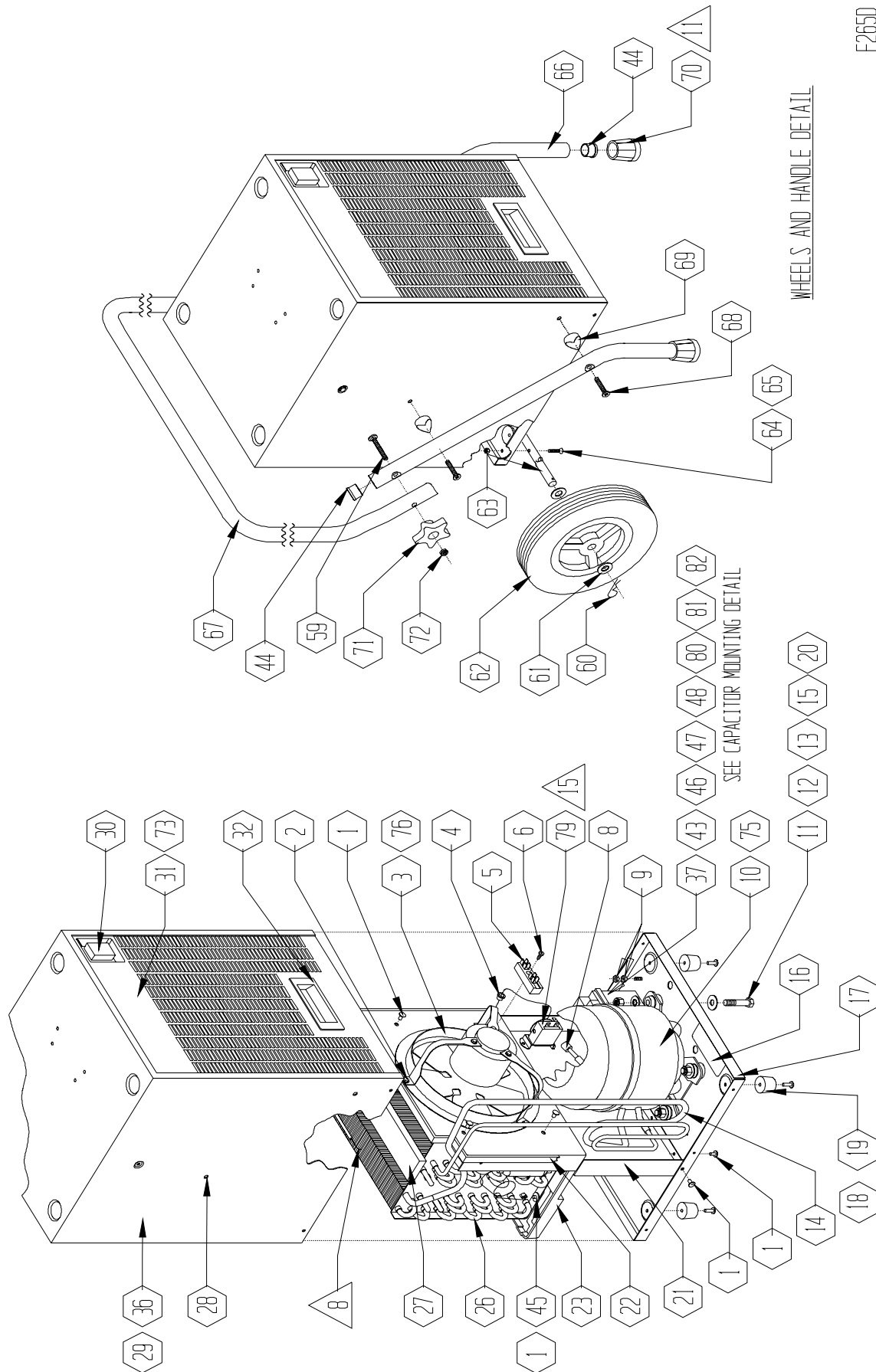

F265D